

THREE-WAY CONTROL VALVES TYPE S3

APPLICATION AREA:

Three-way control valves type S3 are used in automatic systems and remote control systems as low control elements to adjust flow of liquids and gases. Type S3M is designed to mix two streams of medium, whereas type Z3R is designed to split one stream into two. Recommended for application in city-heating and HVAC systems and many branches of industry. They can be delivered with P/R actuators (basic option) or with P1/R1; P3/R3 actuators (upon request) electric actuators, handwheels type 20 or with no drives.

FEATURES:

- wide range of nominal dimensions, DN15...150 for nominal pressures PN10...40; CL150; CL300,
- various materials of valve body and internal parts casts, adapted to specific working conditions,
- wide range of flow coefficients,
- reduction in aggressive and toxic fluids emissions to environment through application of bellow seal bonnets or bonnet packings meeting requirements of TA - LUFT,
- easy assembly and dismantling of valve internal parts for maintenance and service,
- high durability and reliability due to application of top-class materials and surface improvement processes (burnishing, stellite, heat treatment, CrN coatings),
- possibility of mating with P/R multi-spring actuators (basic option), P1/R1. Full reversibility of actuator operation and changing the spring range with no extra parts,
- optional fitting of pneumatic actuators with a handwheel,
- option of diagnostics of "valve - actuator" system, thanks to application of smart electro-pneumatic positioners,
- high tightness of closure due to application of soft seats (PTFE sealing) in the whole range of flow ratios,
- same flow ratios and control characteristics for "hard" (metal-to-metal) and "soft" (metal-gasket) seats,
- reliable connection between actuator stem and valve, and between screwed in seat and body,
- top-class flat sealing and bonnet packing,
- broad range of electric actuators ,
- possibility of mating with handwheels type 20 or NN,
- special executions for oxygen, hydrogen, acidic gases with H₂S content, explosive atmospheres - as per ATEX Directive 94/9/EC,
- competitive prices due to simple and functional design of valves and actuators and materials applied,
- design and production process meet the requirements of Quality Management System ISO 9001 and Directive 97/23/EC, and regulations of AD2000 Merkblatt, designated for installation on pipelines.



DESIGN AND TECHNICAL SPECIFICATION:

Body (1): flanged, cast, with integrated bonnet (cast iron execution) or welded bonnet (cast steel execution).
 Nominal size: DN15; 20; 25; 32; 40; 50; 65; 80; 100; 150 *)
 Nominal pressure: PN10; 16; 25; 40 (as per PN-EN 1092-1:2010 and PN-EN 1092-2:1999);
 CL150; CL300 (as per PN-EN 1759-1:2005) *)

*) higher nominal dimensions [DN] and higher nominal pressures are available after agreement with the manufacturer
 Steel flanges CL150; CL300 are so designed that they can be assembled with flanges executed per American standards ANSI/ASME B16.5 and MSS SP44. In American standards flanges are identified with nominal values in "Classes", to which nominal pressure (PN) values as per PN-ISO 7005-1:2002 correspond.

Equivalent identification as per PN are: CL150: PN 20 and CL300: PN 50.

Table 1. Flanged end connections

Material	Nominal pressure	Facing of flange types			
		Raised face	Groove	Recess	Ring - joint
Identification					
Grey iron	PN10; 16	B ²⁾	-	-	-
Spheroidal iron	PN10; 16; 25; 40		-	-	-
Cast steel	PN10; 16; 25; 40		D	F	-
	CL150		-	-	J (RTJ)
CL300	DL (D1 ¹⁾	F (F1)			
¹⁾ - only for CL300; ²⁾ - B1 - (Ra=12.5 mm, concentric surface structure "C"), B2 - (Ra as agreed with the customer); () - identification of connections as per ASME B16.5					
Possible execution of flanges per specification and indicated standards					

face-to-face dimensions (body): as per PN-EN 60534-3-1; 2000r; series 1 - for PN10; 16; 25; 40; series 37- for CL150; series 38 - for CL300

Bonnet (1a) - standard or extension bonnet integrated with body; cast or welded depending on material - refer to Table 3

Stub (2) - flanged: steel (rod); stub offset from axis as per Fig.5; Table 14

Valve plug (3) - contoured-piston (with side type cuts), linear control characteristics
 - rangeability 50:1

Seats (4) - screwed in (4.1) and fitted-in (4.2): • hard, • soft with PTFE packing

Valve plug stem (5) - burnished or toughened with polished sealing face.

Sealing (7,8) - body gaskets: spiral type, "graphite+1.4404", bonnet gaskets: as per Table 2.

Table 2. Packing types with application ranges.

Packing	PN / CL	Temperature [°C] / Bonnet	
		Standard	Extension
PTFE-V	PN10...CL300	-46...+200	-198...-46
PTFE + Graphite			+200...+300
PTFE-V / TA-LUFT		+200...+300	+300...+450
Graphite			
Graphite / TA-LUFT			

Leakage class:
 - basic: Class IV as per PN-EN 60534-4 - hard valve seat
 - bubble-tight: Class VI as per PN-EN 60534-4 - soft valve seat

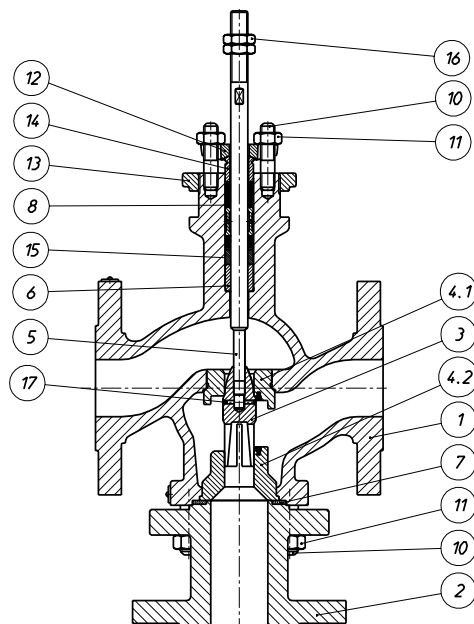

Fig.1. Control valve

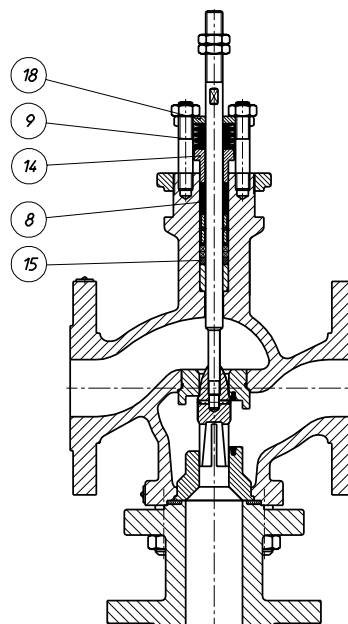

Fig.2. Control valve with TA-LUFT sealing

Special designs: Control valve with below seal and control valve with welded ends. (dimensions must be agreed with producer.)

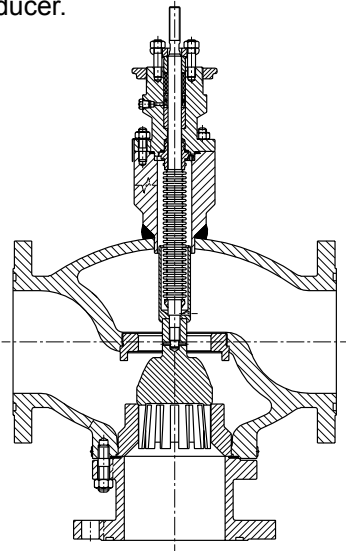
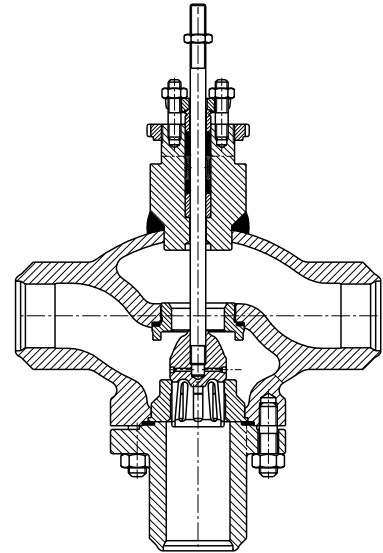

Fig. 3. Control valve with below seal



Rys. 4. control valve with welded ends

Table 3. Listing of components with materials

Poz.	Component	Materials							
		EN-GJL 250 (EN-JL 1040)	EN-GJS 400-18 LT (EN-JS 1025)	GP 240 GH ; (1.0619)	WCB	G20Mn5 (1.6220)	GX5CrNiMo 19-11-2 (1.4408)	CF8M	
1	Body								
1a	Bonnet			S 355 J2G3(1.0570)		G20Mn5 (1.6220)	X6CrNiMoTi 17-12-2 (1.4571)		
2	Stub		S 355 J2G3 (1.0570)			P355 NL2 (1.1106)	X6CrNiMoTi 17-12-2 (1.4571)		
3	Plug			X6CrNiMoTi 17-12-2 (1.4571) X6CrNiMoTi 17-12-2; (1.4571) + stellite + CrN X17CrNi 16-2; (1.4057) + heat treatment					
4.1	Screwed in seat			X6CrNiMoTi 17-12-2; (1.4571)					
4.2	Fitted in seat			X6CrNiMoTi 17-12-2; (1.4571) + stellite X6CrNiMoTi 17-12-2; (1.4571) + PTFE X17CrNi 16-2; (1.4057) + heat treatment					
5	Stem			X6CrNiMoTi 17-12-2; (1.4571) X17CrNi 16-2; (1.4057);					
6	Guiding sleeve			X6CrNiMoTi 17-12-2; (1.4571) + CrN X17CrNi 16-2; (1.4057) + CrN					
7	Body gasket			Grafit (98%) + 1.4404 (spiral)					
8	Packing kit			PTFE + GRAFIT PTFE - „V” GRAFIT					
9	Disk spring			12R10 (SANDVIK)					
10.1	Bolt		8.8						A4 - 70
10.2									
11.1	Nut		8						A4 - 70
11.2									
12	Press lever			C45					
13	Fixing nut			X6CrNiMoTi 17-12-2; (1.4571)					
14.1	Press sleeve			X6CrNiMoTi 17-12-2; (1.4571)					
14.2									
15.1	Spacer sleeve			X6CrNiMoTi 17-12-2; (1.4571)					
15.2									
16	Nut (low)		C45						X6CrNiMoTi 17-12-2; (1.4571)
17	Peg			X6CrNiMoTi 17-12-2; (1.4571)					
18	Compression plate			X6CrNiMoTi 17-12-2; (1.4571)					
Relevant material standards									
Material		Numer normy							
EN-GJL 250 ; (EN-JL 1040)		PN-EN 1561							
EN-GJS 400-18 LT ; (EN-JS 1025)		PN-EN 1563							
GP 240 GH ; (1.0619)		PN-EN 10213-2							
WCB		ASTM A 216							
G20Mn5 ; (1.6220)		PN-EN 10213-3							
GX5CrNiMo 19-11-2 ; (1.4408)		PN-EN 10213-4							
CF8M		ASTM A 351							
S 355 J2G3 ; (1.0570)		PN-EN 10025							
P355 NL2 ; (1.1106)		PN-EN 10028-3							
X6CrNiMoTi 17-12-2 ; (1.4571)		PN-EN 10088							
X17CrNi 16-2 ; (1.4057)		PN-EN 10088							
C45		PN-EN 10083-1							

NOTE:

Hardening method used for hardening of valve internal parts comprises:

- a) stellite – padding of surfaces with stellite: ~40HRC
- b) CrN coating – introducing chromium nitride to external layer of detail, to the depth of ca.0.1 mm:~950HV
- c) heat treatment: valve plug (~45HRC), valve seat (~35HRC), guiding sleeve (~45HRC)

Table 4...10. Allowable working overpressure for materials at proper temperatures

Table 4.		Material: EN-GJL 250 as per PN-EN 1561						
PN	Standard	Temperature [°C]						
		-10...120	150	180	200	230	250	300
		Allowable working pressure [bar]						
PN10	PN-EN 1092-2	10	9	8,4	8	7,4	7	6
PN16		16	14,4	13,4	12,8	11,8	11,2	9,6

Table 5.		Material: EN-GJS 400-18 LT as per PN-EN 1563					
PN	Norma	Temperature [°C]					
		-10...120	150	200	250	300	350
		Allowable working pressure [bar]					
PN10	PN-EN 1092-2	10	9,7	9,2	8,7	8	7
PN16		16	15,5	14,7	13,9	12,8	11,2
PN25		25	24,3	23	21,8	20	17,5
PN40		40	38,8	36,8	34,8	32	28

Table 6.		Material: GP240GH (1.0619) as per PN-EN 10213-2								
PN / CL	Norma	Temperature [°C]								
		-10...50	100	150	200	250	300	350	400	
		Allowable working pressure [bar]								
PN10	EN 1092-1	10	9,2	8,8	8,3	7,6	6,9	6,4	5,9	
PN16		16	14,8	14	13,3	12,1	11	10,2	9,5	
CL150	PN-EN 1759-1	17,3	15,4	14,6	13,8	12,1	10,2	8,4	6,5	
PN25	EN 1092-1	25	23,2	22	20,8	19	17,2	16	14,8	
PN40		40	37,1	35,2	33,3	30,4	27,6	25,7	23,8	
CL300	PN-EN 1759-1	45,3	40,1	38,1	36	32,9	29,8	27,8	25,7	

Table 7.		Material: GX5CrNiMo 19-11-2 (1.4408) as per PN-EN 10213-4										
PN / CL	Norma	Temperature [°C]										
		-10...50	100	150	200	250	300	350	400	425	450	
		Allowable working pressure [bar]										
PN10	EN 1092-1	10	10	9	8,4	7,9	7,4	7,1	6,8	-	6,7	
PN16		16	16	14,5	13,4	12,7	11,8	11,4	10,9	-	10,7	
CL150	PN-EN 1759-1	17,9	16,3	14,9	13,5	12,1	10,2	8,4	6,5	5,6	4,7	
PN25	EN 1092-1	25	25	22,7	21	19,8	18,5	17,8	17,1	-	16,8	
PN40		40	40	36,3	33,7	31,8	29,7	28,5	27,4	-	26,9	
CL300	PN-EN 1759-1	46,7	42,5	38,9	35,3	32,9	30,5	28,8	27,6	27,2	26,9	

Table 8.		Material: G20Mn5 (1.6220) wg PN-EN 10213-3					
PN / CL	Norma	Temperature [°C]					
		-40	100	150	200	250	300
		Allowable working pressure [bar]					
PN10		6	6	3,8	3,6	3,48	3,4
PN16		16	16	10,1	9,6	9,28	9,07
PN25		25	25	15,8	15	14,5	14,2
PN40		40	28	28	27	26	25

Table 9.		Material: WCB as per ASTM A216									
PN / CL	Norma	Temperature [°C]									
		-10...50	100	150	200	250	300	350	375	400	
		Allowable working pressure [bar]									
PN10	EN 1092-1	10	10	9,7	9,4	9	8,3	7,9	7,7	6,7	
PN16		16	16	15,6	15,1	14,4	13,4	12,8	12,4	10,8	
CL150	PN-EN 1759-1	19,3	17,7	15,8	14	12,1	10,2	8,4	7,4	6,5	
PN25	EN 1092-1	25	25	24,4	23,7	22,5	20,9	20	19,4	16,9	
PN40		40	40	39,1	37,9	36	33,5	31,9	31,1	27	
CL300	PN-EN 1759-1	50	46,4	45,1	43,9	41,8	38,9	36,9	36,6	34,6	

Table 10.		Material: CF8M as per ASTM A351											
PN / CL	Norma	Temperature [°C]											
		-10...50	100	150	200	250	300	350	375	400	425	450	
		Allowable working pressure [bar]											
PN10	EN 1092-1	8,9	7,8	7,1	6,6	6,1	5,8	5,6	5,5	5,4	5,4	5,3	
PN16		14,3	12,5	11,4	10,6	9,8	9,3	9	8,8	8,7	8,6	8,5	
CL150	PN-EN 1759-1	18,4	16	14,8	13,6	12	10,2	8,4	7,4	6,5	5,6	4,6	
PN25	EN 1092-1	22,3	19,5	17,8	16,5	15,5	14,6	14,1	13,8	13,6	13,5	13,4	
PN40		35,6	31,3	28,5	26,4	24,7	23,4	22,6	22,1	21,8	21,6	21,4	
CL300	PN-EN 1759-1	48,1	42,3	38,6	35,8	33,5	31,6	30,4	29,6	29,3	29	29	

NOTES:

1. It is allowed to apply spheroidal iron, carbon steel and acid proof cast steel for temperatures lower than given in Tables 4...10, provided that working pressure is reduced respectively, working temperature impact tests are performed and cast is heat treated. Details are to be consulted with manufacturer.
2. Working pressure for intermediate temperature values can be calculated by interpolation.

Table 11: Kvs flow ratios and calculation coefficients (design).

Kvs	0,63	1,0	1,6	2,5	4,0	6,3	10	16	25	40	63	94	125	160	250	320	
Stroke [mm]	20										38				50		
Seat dia. [mm] D	12,7			19,05		20,64	25,25	31,72	41,25	50,8	66,7	88,9		107,92	126,95		
DN	15																
	20																
	25																
	32																
	40																
	50																
	65																
	80																
	100																
150																	
Metallic seat	F_D [kN]	0,2	0,3		0,33	0,4		0,5	0,7	0,8	1,1	1,4		1,7	2,0		
Soft seat	F_D [kN]	0,25	0,3		0,5	0,5	0,6	0,8	1,0	1,3	1,7	2,2		2,7	3,2		
Calculation coefficients: $F_t = 0,9$; $X_t = 0,7$; $F_d = 0,41$; $x F_2 = 0,65$																	
higher nominal diameters and Kvs flow ratios are available after agreement with the manufacturer																	

ALLOWABLE PRESSURE DROPS Δp .

Pressure drops Δp [bar] refer to closed valve and they are calculated for valve drive potential. Actual pressure drops should not exceed 70% of allowable working pressure for given nominal pressure, material execution and working temperature, as per tables 4...10.

$$\Delta p = \frac{F_s - F_D}{0,785 \cdot 10^{-4} \cdot D^2} \quad \text{or} \quad F_s = 0,785 \cdot 10^{-4} \cdot D^2 \cdot \Delta p + F_D$$

- where
- Δp [bar] - calculated pressure drop
 - F_s [kN] - actuator available force (Table 11)
 - F_D [kN] - valve plug to valve seat pressure (Table 10)
 - D - valve seat diameter [mm] (Table 10)

Table 12: Available force F_s [kN] of pneumatic actuators

Actuator size	Direct actuator P			Reverse actuator R					
	Supply pressure [kPa]			Spring range [kPa]					
	140	250	400	20 - 100	40 - 120; 40 - 200	60 - 140	80 - 240	120 - 280	180 - 380
160	0,64	2,4	4,8	0,32	0,64	0,96	1,28	1,92	-
250	1,0	3,8	7,5	0,5	1,0	1,5	2,0	3,0	-
400	1,6	6,0	12,0	0,8	1,6	2,4	3,2	4,8	-
630	2,5	9,5	18,9	1,3	2,5	3,8	5,0	7,6	11,3
1000	4,0	15,0	30,0	2,0	4,0	6,0	8,0	12,0	18,0

- NOTE:**
- For direct actuators P adopted spring range is 20 - 100 kPa
 - For electric and other actuators Δp value can be calculated using above formula and data from Tables 12 and 14, taking nominal load capacity as available force F_s , as per actuator catalog chart.

When using pneumatic actuators their available forces are to be calculated separately for extreme position of stem, accounting for operation (direct or reverse), and valve operation (mixing or separation). To facilitate and simplify selection of pneumatic actuators spring ranges and supply pressures were unified, regardless of operation (simple or reverse). For parameters of pneumatic actuators to be used in calculation of available forces refer to Tables 13 and 13a.

Table 13 i 13a. Technical specification of pneumatic actuators

Parameter	Unit	Spring range					
$p_1 - p_2$	[kPa]	20...100	40...120	60...140	80...240	120...280	180...380
p_z	[kPa]	250			400		
A_s	[cm ²]	160; 250; 400; 630; 1000					630; 1000
Actuator type		P / R					
Size		160	250	400	630	1000	
H [mm]		20			38	38; 50; 63	

where: H - stroke [mm]
 $p_1 \div p_2$ - spring range [kPa]; p_z - supply pressure [kPa];
 A_s - effective area of actuator diaphragm [cm²];

Available force of pneumatic actuators F_s [kN] is to be derived from below formulas, regarding valve function, actuator operation and pressure point (top or bottom port)

a) Valve function: mixing

$$\begin{aligned} F_{SP1} &= 10^{-4} p_1 \cdot A_s & ; & & F_{SR1} &= 10^{-4} (p_z - p_2) \cdot A_s \\ F_{SP2} &= 10^{-4} (p_z - p_2) \cdot A_s & ; & & F_{SR2} &= 10^{-4} p_1 \cdot A_s \end{aligned}$$

b) Valve function: diverting

$$\begin{aligned} F_{SP1} &= 10^{-4} (p_z - p_1) \cdot A_s & ; & & F_{SR1} &= 10^{-4} p_2 \cdot A_s \\ F_{SP2} &= 10^{-4} p_2 \cdot A_s & ; & & F_{SR2} &= 10^{-4} (p_z - p_1) \cdot A_s \end{aligned}$$

Interpretation concerning individual available forces F_s of pneumatic actuators:

- F_{SP1} - direct P actuator; closed screwed-in port (top),
- F_{SP2} - direct P actuator; closed fitted-in port (bottom),
- F_{SR1} - direct R actuator; closed screwed in port (top),
- F_{SR2} - direct R actuator; closed fitted-in port (bottom).

NOTE:

Ranges 20...100kPa and 180...380kPa are not recommended for mixing function due to high difference between available forces for top and bottom port.

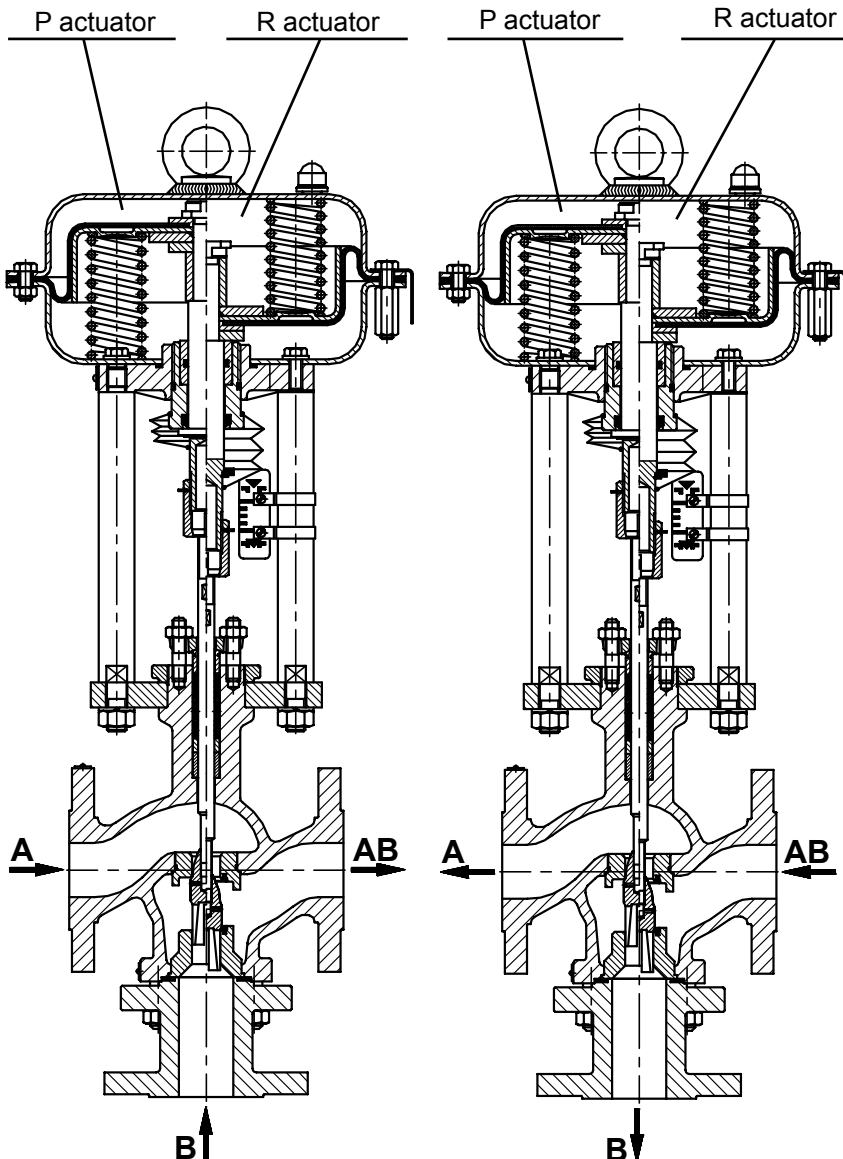

Fig.5. P/R-S3M - Mixing

Fig.6. P/R-S3R - Diverting

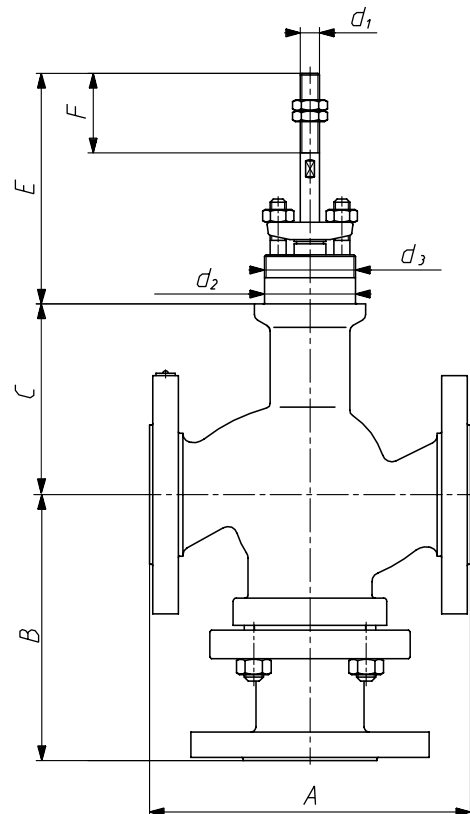

Fig.7. External and connection dimensions

Table 14. Control valves connection dimensions

Dimensions		Unit	DN									
			15	20	25	32	40	50	65	80	100	150
A	PN10; 16; 25; 40	[mm]	130	150	160	180	200	230	290	310	350	480
	CL150		-	-	184	-	222	254	-	298	352	451
	CL300		-	-	197	-	235	267	-	317	368	473
B		[mm]	140			162		184	215,5	233,5	240	295
C	Standard bonnet	[mm]	97			110	117	128	140	146	171	205
	Extension bonnet		297			310	317	328	340	346	371	405
E ¹⁾		[mm]	125									195 ^{*)}
F		[mm]	50									100
d ₁		[mm]	M12x1,25									M16x1,5
d ₂		[mm]	57,15									84,15
d ₃		-	2 1/4"-16UN2A									3 5/16"-16NS2A
Weight		[kg]	8,5	10,5	12	15	18	26,5	36	55	75	150
¹⁾ - valve in closed position, fitted-in bottom port; ^{*)} - dimension for P/R-1000, for actuators P1/R1 E=125; F=80 higher nominal dimensions [DN] are available after agreement with the manufacturer												

Table 15. Application of pneumatic actuators

Actuators	DN										
	15	20	25	32	40	50	65	80	100	150	
P / R - 250											
P / R - 400											
P / R - 630											
P / R - 1000											

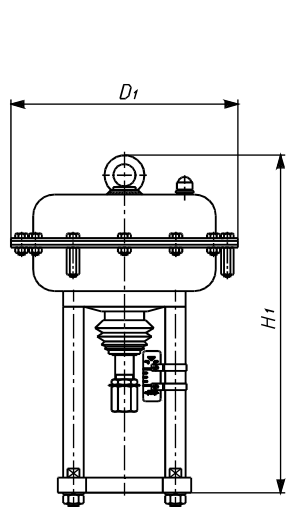

Fig.8. Actuators P/R, PN/RN

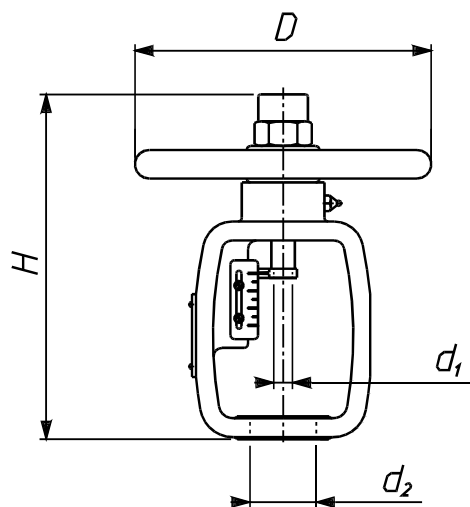
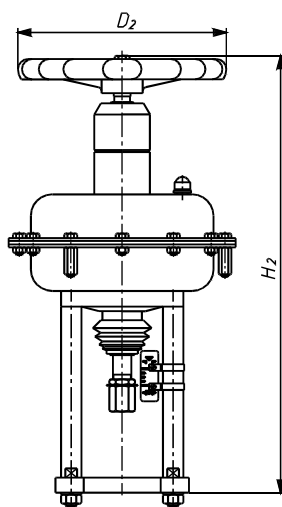

Fig.9. Handwheel type 20

Table 16: Sizes and weights of pneumatic actuators P/R and PN/RN - Fig.6.

Actuator size	D ₁	D ₂	H ₁	H ₂	Weight [kg]	
	mm				P/R	PN/RN
250	240	225	377	474	10	14,5
400	305		385	484	16	20,5
630	375	305	477	574	30	37
1000	477	450	660	835	74	100

Table 17: Types, sizes and weights of handwheels type 20 - Fig.7.

Type	Stroke [mm]	d ₁	d ₂	H	D	Rev. / stroke	Weight [kg]
20-20-57-M12	20	M12x1,25	57,15	265	228	8	7,5
20-38-57-M12	38				298	15	10
20-38-84-M16	50	M16x1,5	84,15		385	16	16
20-50-84-M16				457			

Marking method:

Example: 20-38-57-M12 - handwheel type 20; stroke 38 mm; d₂=57.15mm; d₁=M12x1.25

CLASSIFICATION AND MARKING:



S3M
S3R

Type:

- pneumatic with direct action:	P
- pneumatic with reverse action:	R
- pneumatic with top handwheel	PN; RN
- electric:	E
- manual	20

Bonnet:

- standard:	1
- extension:	2
- other	X

Packing:

- PTFE, braided	A
- PTFE, V	B
- PTFE, for oxygen	C
- graphite, braided	D
- graphite, expanded	E
- TA-Luft, PTFE	F
- TA-Luft, graphite	G

Leakage class:

- basic: class IV	4
- bubble-tight: class VI	6

Valve plug:

- unbalanced	7
--------------	----------

Choke cages:

- no choke cages	0
------------------	----------

Plug characteristics and type:

- linear, contoured-piston	L
- other	X

Body material:

- grey iron	1
- spheroidal iron	2
- carbon steel	3
- stainless steel	5
- other	X

MARKING EXAMPLE:

Control valve type S3, mixing function, reverse action pneumatic actuator with top-mounted handweel, extension bonnet, expanded graphite stem seal, leakage class IV, execution in stainless steel:

RN-S3M-2E470L5

Marking is shown on valve nameplate.

Additional information:

- nominal size [DN],
- nominal pressure [PN],
- max working temperature [TS],
- max working pressure [PS],
- test pressure [PT],
- flow coefficient [Kvs],
- plug stroke [H],
- fluid group [1 or 2],
- serial number and year of manufacture.

ORDERING:

The order should contain all information as per data questionnaire. Full information can be obtained from the Sales and Marketing Department or Technical Department.